

SLW110 Technical Data Sheet

SLW110 Series Pedestal Supports are used to construct raised floors at varying heights from 85mm up to 660mm and more. These modular supports used in joist framing and installations with decking or composite flooring materials. Thanks to 'self-levelling modul' provide automatic slope correction on surfaces maximum up to 5% gradient.

SLW110 Product Features

Raw Material	Polypropylene
Height Range	Min. 85 mm - Max. 660 mm
Base Diameter	187 mm
Base Wall Thickness	3 mm
Head Diameter	126 mm
Laying Surface of the Base	302 cm ²
Slope Correction	% 5
Enviromental Impact Assessment	Eco - Friendly
Application Areas	Can be used for all indoor and outdoor areas. Also, on levelled surfaces, epoxy or membrane insulated in areas.
Application	Using any of fixing material is not necessary. Optionally, the modules can be fixed to the application surface using adhesive or screw.

SLW110 Technical Drawing

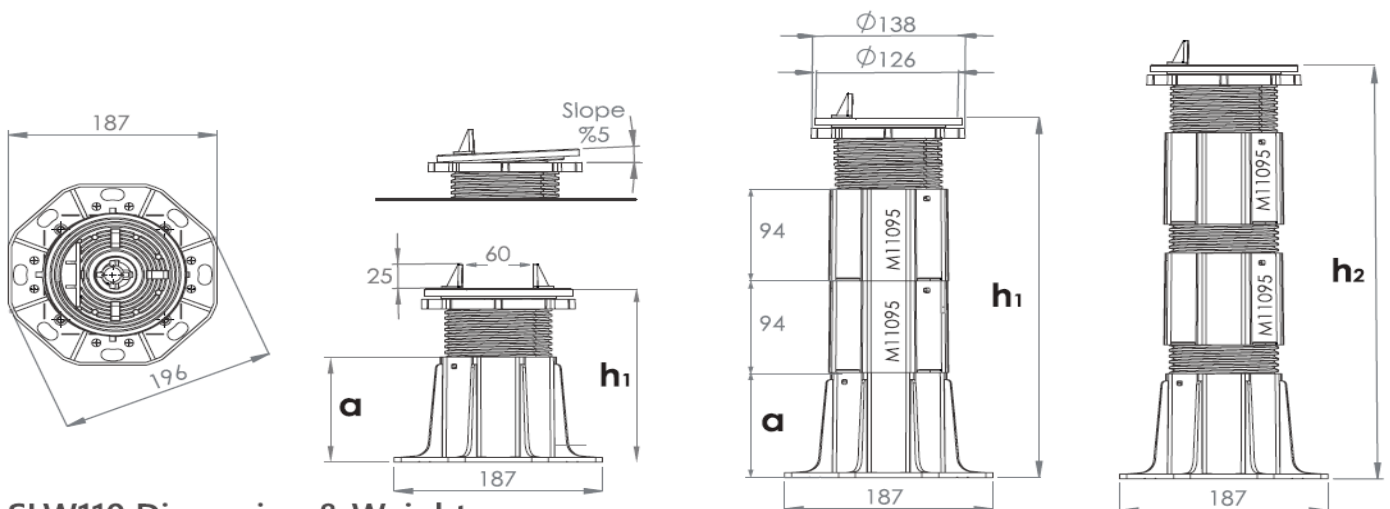

SLW110 Dimension & Weight

Model	SLW110-04	SLW110-05	SLW110-06	SLW110-07	SLW110-08	SLW110-09	SLW110-10	SLW110-11	SLW110-12	SLW110-13
a	65 mm	109 mm	65 mm	109 mm	65 mm	109 mm	65 mm	109 mm	65 mm	109 mm
h1(min.- max)	85-135 mm	130-180 mm	180-228 mm	224-272 mm	273-322 mm	317-366 mm	367-415 mm	410-460 mm	460-510 mm	505-553 mm
h2	-	-	255 mm	300 mm	377 mm	420 mm	497 mm	540 mm	617 mm	660 mm
Extension	-	-	M11095	M11095	M11095	M11095	M11095	M11095	M11095	M11095
Weight	0,414 gr	0,486 gr	-	-	-	-	-	-	-	-
Comp.			 x1	 x1	 x2	 x2	 x3	 x3	 x4	 x4

SLW110 Pressure Resistance

Pressure measuring point

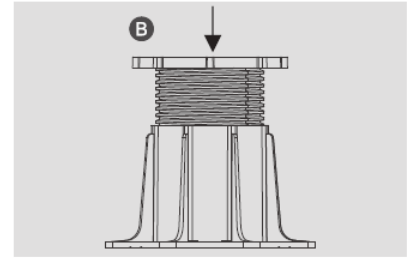
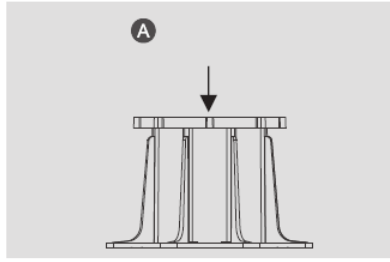

A Minimum highness

COMPRESSION TEST (HOT 23°)

B Maximum highness

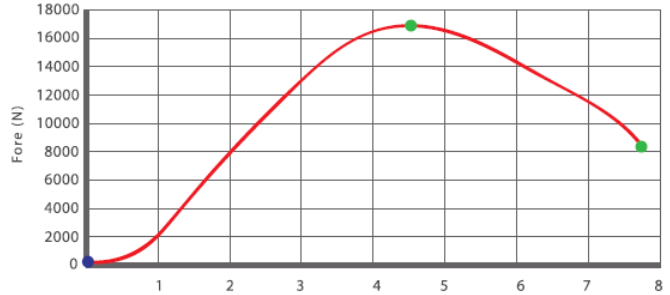
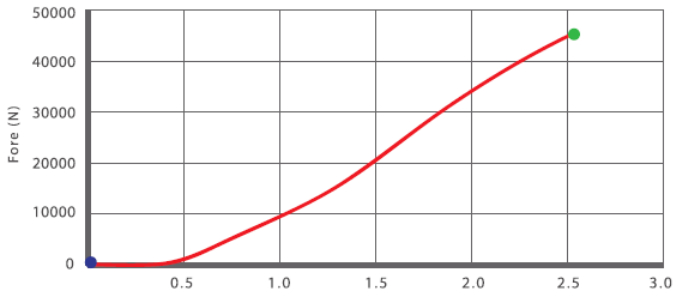

A Minimum highness

COMPRESSION TEST (COLD -40°)

B Maximum highness

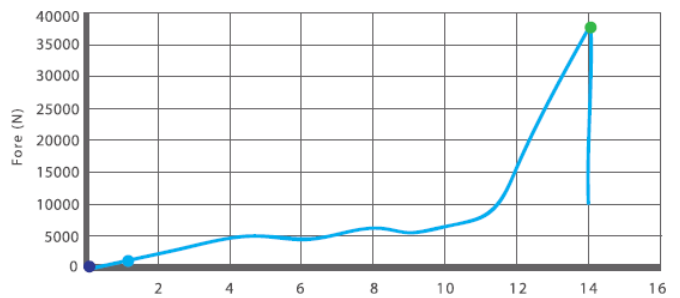
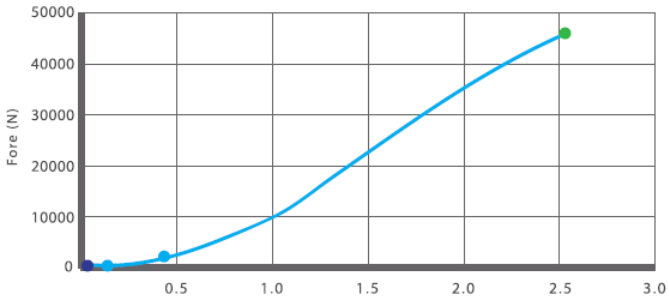

TESTED AND APPROVED BY HEADSHIP OF TURKISH STANDARDS INSTITUTION (TSE) AND CALIBRATION CENTER CONSTRUCTION MATERIALS LABORATORY (ANKARA CITY)

SLW110 Packaging Information

Product code	SLW110-04	SLW110-05	SLW110-06	SLW110-07	M11095
Pcs per box	24*	20*	16*	14*	24**
Gross weight per box	11,40 kg	11,45 kg	11,80 kg	11,25 kg	5,40 kg
Boxes per pallet	12	12	12	12	24
Box dimensions	60cm x 40cm x h=40cm *		40cm x 30cm x h=41cm **	40cm x 30cm x h=20cm ***	
Gross weight per pallet	162 kg	162 kg	167 kg	160 kg	155 kg
Pallet dimensions	cm 80 x 120 x h140				

* Products are packed in cardboard boxes. Shrink-wrapped euro-pallets are used for final packaging. In spite of being shrink-wrapped and rain proof packagings, recommended to keep the pallets in closed area.

